

Mod. K1

Trailer for monitors

Standard characteristics

Trailer material: Carbon steel

Typology: Single-axle trailer

Hose boxes suitable for n. 2 hoses
(for hoses, see dedicated page)

Parking brake with deadbolt

Flanged connection for monitor (see compatible monitor)

Feeding: Double way with internal clapet

Pneumatic tires

Coating: Epoxy Primer + Polyuretanic red coat RAL3000,
Total DFT >120 µm

Empty Weight: ~95 Kg

Approvals

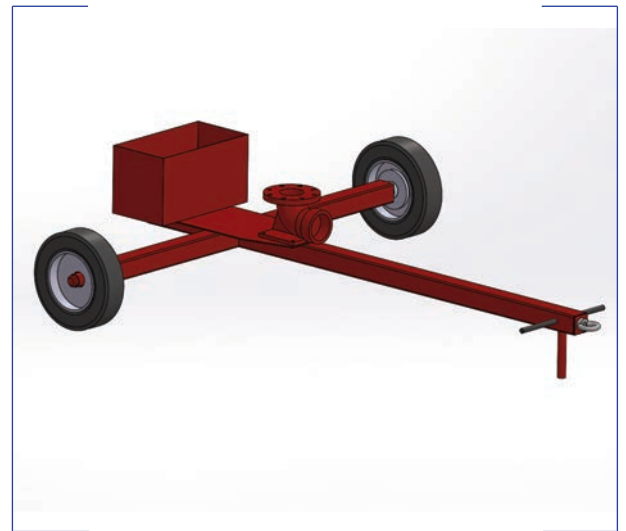

Notes

In case of inquiry and/or order specify the following datas:

- > Type of monitor, hose lenght, feeding connection type

Compatible monitors

- > MB3, MB4, DOC, MKW, MKL

Available on Demand

- > Feeding: Triple way feeding
- > Hot dip galvanized trailer frame
- > Solid tires
- > Coating: Other painting cycles

Optional

- > Box suitable for n.° 3 hoses

www.fasspa.net

Mod. K1

Trailer for monitors

Layout & Overall Dimension

