

## Mod. NV-N

Steam hose reel

### Standard characteristics

**Mounting position:** On the floor

**Side supports material:** Carbon steel

**Rotating joint material:** Brass

**Discs Material:** Stainless steel

**NV-N Delivery hose:** Non collapsable reinforced rubber, black Ø3/4", Ø1" jointed with clamps, available in 20, 30 meters

**Maximum steam temperature (with rubber hose):** 210° C

**Coating:** Epoxy Primer + Polyuretanic red coat RAL3000, Total DFT >120 µm

**NV-N Weight:** NV-3/4"-20-N ~37 Kg

NV-1"-30-N ~43 Kg

NV-3/4"-20-N ~43 Kg

### Approvals

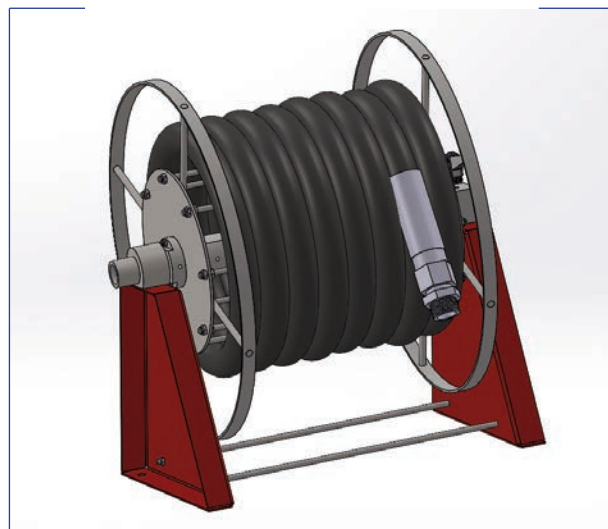

### Notes

In case of inquiry and/or order specify the following datas:

- > Diameter and lenght of hose reel

### Optional

In case of inquiry and/or order specify the following datas:

- > Hose rewind lever
- > Feeding interception valve
- > Mounted on frame and/or in cabinet

### Available on Demand

- > Flanged inlet connection
- > Hoses different from standard
- > Coating: Other painting cycles

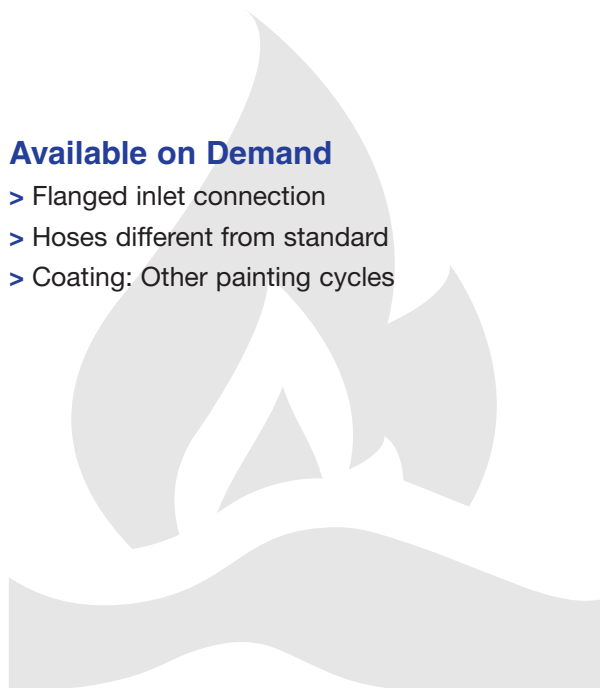

[www.fasspa.net](http://www.fasspa.net)



# Mod. NV-N

Steam hose reel

## Layout & Overall Dimension

