

MONITOR MKL KEY CONFIGURATION

Mod. MKL-A - Application for self oscillating

Standard characteristics

Body Size: 3"

Automatic oscillation with hydraulic motor: From 0° to 360° continuous, by step 30°

Elevation and deflection with lever: ~ +85° - 40°

Weight: ~42 Kg

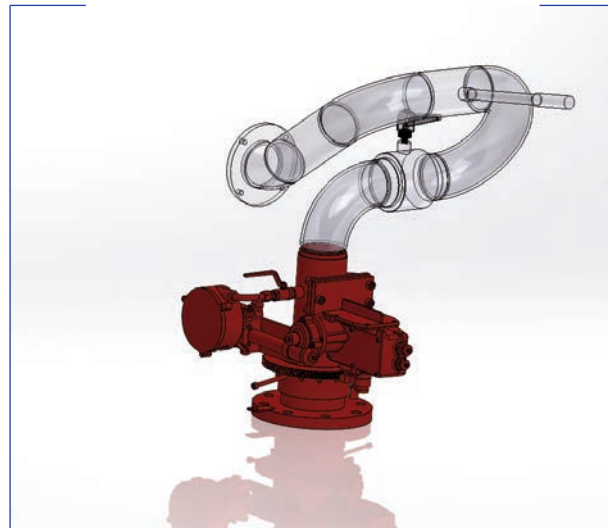

Available on Demand

> Self Oscillating device with lever for neutral position



Layout & Overall Dimension - MKL Monitor self oscillating

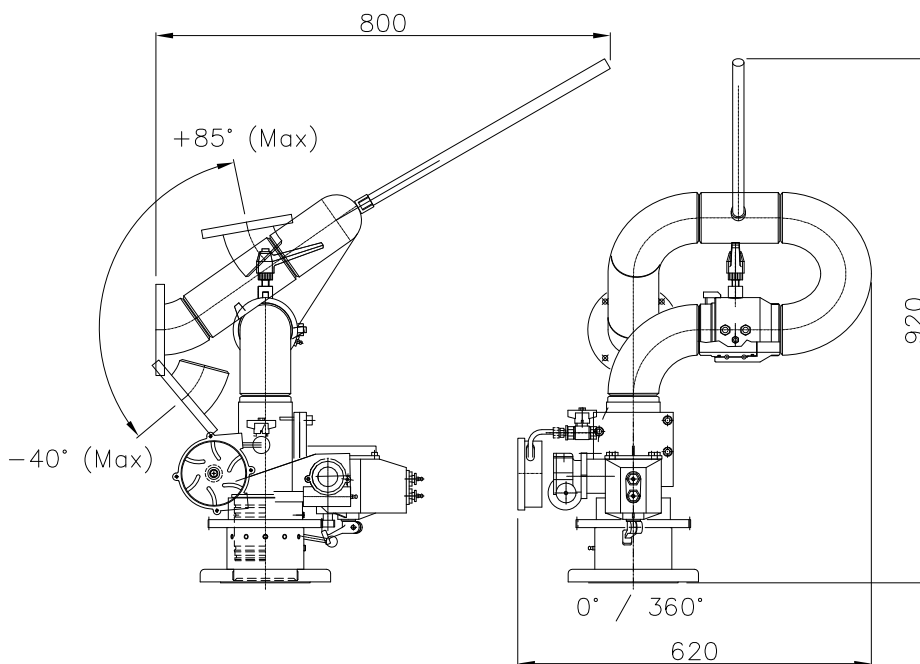

www.fasspa.net